



BCM 2604

V1.1



© Baracoda™ - October 2003

Baracoda, Inc. (US Office)
45 Main street - Suite 616 - Brooklyn, NY 11201
Ph: 718 488 9600 - Fx: 718 488 9601

Baracoda SA (Europe Office: France)
30 Avenue de l'Amiral Lemonnier - 78160 Marly-Le-Roi
Ph: +33 1 30 08 89 00 - Fx: +33 1 30 08 89 98



The bluetooth name and Bluetooth registered trademarks are owned by Bluetooth SIG, Inc., and are used by Baracoda under license. The Baracoda names and Baracoda trademarks are own by Baracoda. All specification are subject to change without notice - Non contractual pictures © Baracoda - All rights reserved

SUMMARY

INTRODUCTION	2
Functional schema:	3
MMI:	3
Definition of flicking times:	4
PROTOCOL OF COMMUNICATION	5
1. Between the REMOTE APLICATION and the SmartModule	5
1.1. Format Cradle of packet.....	5
1.2. Remote application to the SmartModule	5
1.2.1. Commands	5
1.2.2. Details of commands	6
1.2.3. Specials commands	11
1.3. SmartModule to the remote application.....	13
1.3.1. Events	13
1.3.2. Details of events.....	13
2. Between the REMOTE APPLICATION and the decode board.....	18
2.1. Remote application to the decode board	18
2.1.1. Commands	18
2.2. Sending of barcodes (decode board to the remote application)	19
2.2.1. Possibilities.....	19
2.2.2. Management of acknowledgment	20
• Barcode_Ack command format	20
• Examples.....	20

INTRODUCTION

This document aims to detail all the protocol of communication between each entity of the BCM2604-L

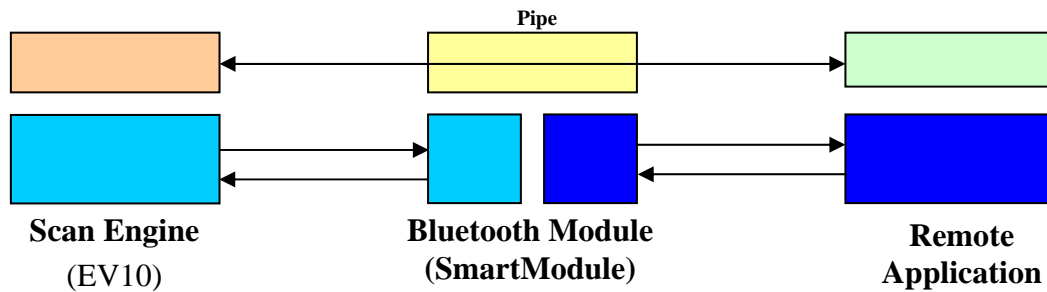

By default the Bluetooth Module forwards all data to the decode board (pipe mode). In order to configure the SmartModule, you need to break the pipe by sending the command:

0x01	0x01	0x01
------	------	------

3 bytes

Then to reestablish the pipe, you must send the command:

0x01	0x02	0x01
------	------	------

3 bytes

Functional schema:

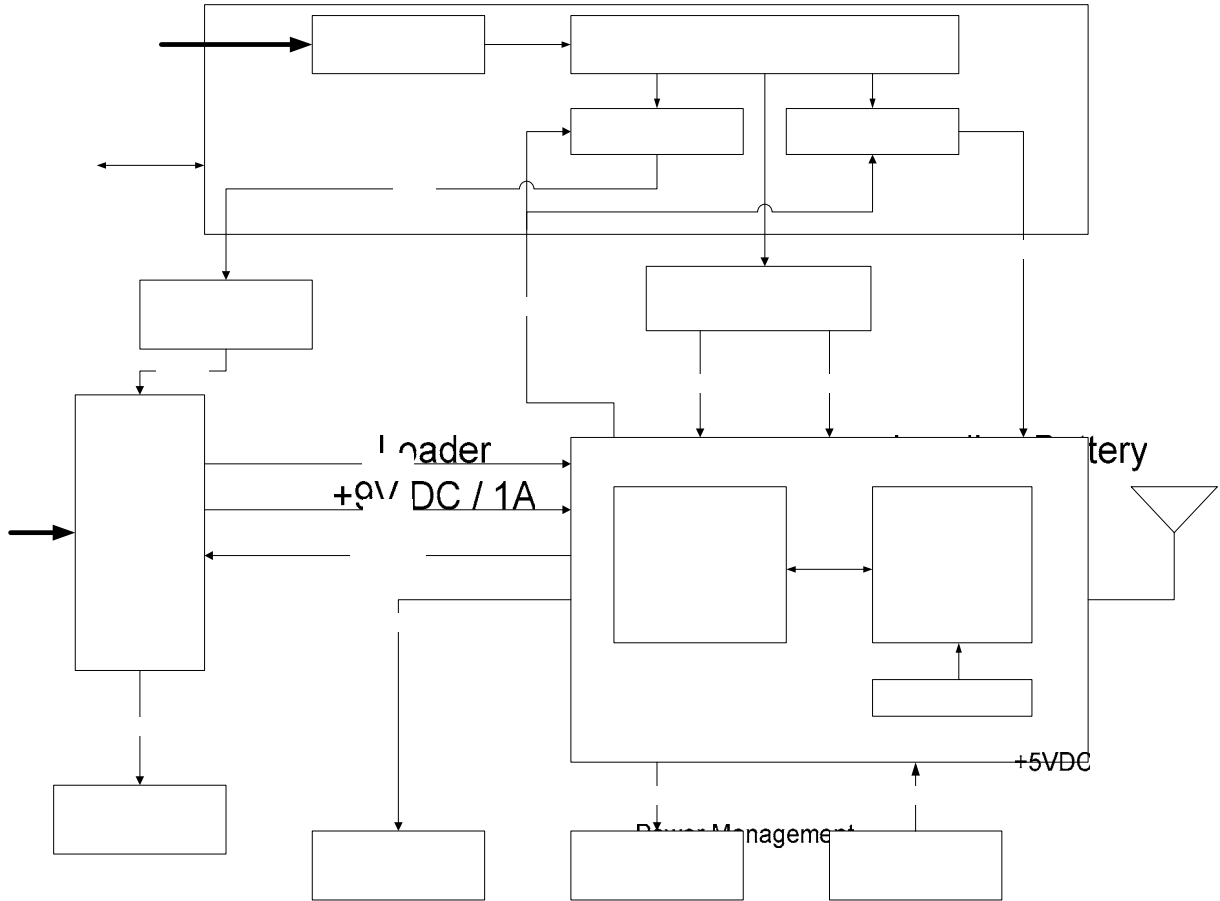

MMI:

Voltage regulator
LDO 3.3VDC

Power_OFF

The following table is describing the user interface, which should be installed on the final product.

+3.3VDC

Events	MMI	
	LED	Buzzer
Battery Charging	Red : fix	nothing
End of charge / full	nothing	nothing
Barcode Real time mode Connected	Green: 3 flashes Green : 2 flashes	3 beeps 1 beep at the connection
No connected	Green : 1 flash	2 beeps at the disconnection
Others		
Success of scan + decode	Green : 1 flashes	1 beep
Acknowledge from the host	Green : 2 flashes	2 beeps

Definition of flicking times:

One flash:

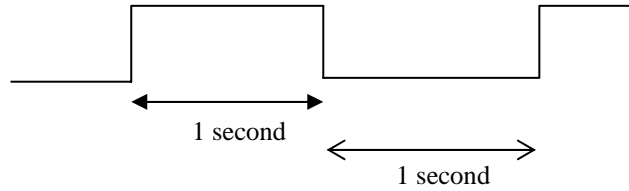

Two flashes:

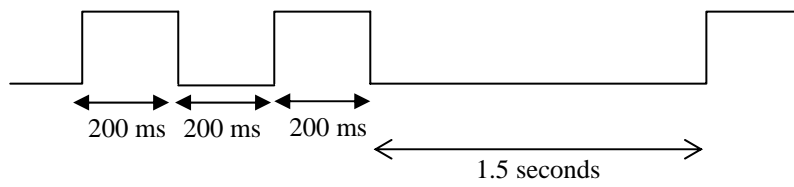

N beep(s):

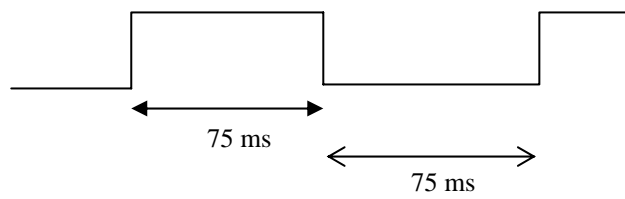

PROTOCOL OF COMMUNICATION

1. Between the REMOTE APPLICATION and the SmartModule

1.1.Format Cradle of packet

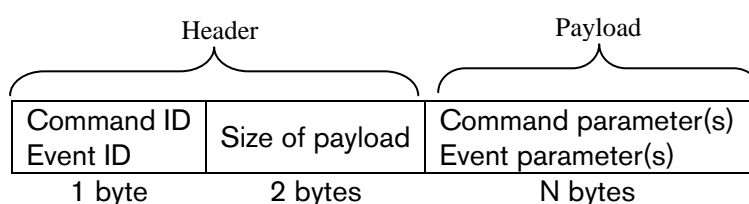

Before sending SmartModule commands, do not forget to break the pipe by sending the command "0x01 0x01 0x01".

1.2.Remote application to the SmartModule

1.2.1. Commands

Command ID	Size (bytes)	Name	Return
0x01	N • 16	Set Pin Code	Ack (see description below)
0x07	0	Get Pin Code	Pin_Code
0x02	N • 248	Set Name	Ack (see description below)
0x08	0	Get Name	Name
0x03	1	Set Mode	Ack (see description below)
0x04	0	Get Mode	Mode
0x09	4	Set Sniff	Ack (see description below)
0x10	0	Get Sniff	Sniff
0x21	N • 17	Set Security Mode	Ack (see description below)
0x20	0	Get Security Mode	Security_Mode
0x19	2	Set Link Time Out	Ack (see description below)
0x18	0	Get Link Time Out	Link_Tmo
0x05	6	Set Remote BDA	Ack (see description below)
0x06	0	Get Remote BDA	Remote_BDA
0x14	4	Set PageScan	Ack (see description below)
0x13	0	Get PageScan	PageScan
0x16	4	Set InquiryScan	Ack (see description below)
0x15	0	Get Inquiry Scan	InquiryScan
0x38	4	Set Power	Ack (see description below)

0x39	0	Get Power	Power
0x32	4	Set Timers	Ack (see description below)
0x33	0	Get Timers	Timers
0x34	N • 41	Set Prefix/Suffix	Ack (see description below)
0x35	0	Get Prefix/Suffix	Prefix/Suffix
0x36	3	Set SendingFormat	Ack (see description below)
0x37	0	Get SendingFormat	Sending Format
0x76	0	Get Versions	Versions

Specials commands:

Command	Name	Return
0x52 0x73 0x74	Reset	None

Description of the ack event:

Command ID	Size	Result
Command ID	0x0001	0x00 → Set command successful 0x01 → Set command failed

1.2.2. Details of commands

- Set Pin Code

This command is used to change the pin code that is used to create a connection when the authentication is enabled.

Command	header		Command parameter(s)	Return parameter(s)
	ID	Size		
Set Pin Code	0x01	N	Pin code	Ack

Parameter	Size	Parameter description
Pin code	N bytes	New pin code (N • 16)

- Set Name

This command is used to change the name of the device.

Command	header		Command parameter(s)	Return parameter(s)
	ID	Size		
Set Name	0x02	N	Name	Ack

Parameter	Size	Parameter description
Name	N bytes	New name (N • 248)

- Set Mode

This command is used to change the operating mode of the device.

Command	header		Command parameter(s)	Return parameter(s)
	ID	Size		
Set Mode	0x03	0x0001	Mode	Ack

Parameter	Size	Parameter description
Mode	1 byte	0x02 → RealTime 0x03 → Lan (default mode)

Lan: all barcodes are transmitted to the remote application. If no connection, barcodes are lost.

RealTime: all barcodes are transmitted to the remote application. If there is no connection, the scanner tries to establish a connection with the device stored in memory (see Set Remote BDA). If it failed, scanned barcodes are lost.

- Set Sniff

This command is used to configure the sniff mode (a low power mode). Higher is the latency, longer is the autonomy. Higher is the latency, slower is the response.

Command	header		Command parameter(s)	Return parameter(s)
	ID	Size		
Set Sniff	0x09	0x0004	MinSniff, MaxSniff	Ack

Parameter	Size	Parameter description
MinSniff	2 bytes	Minimum interval, in slots, for sniff mode negotiation
MaxSniff	2 bytes	Maximum interval, in slots, for sniff mode negotiation

Note: MinSniff • MaxSniff

Range: 0x0012 – 0xFFFF (if N= 0, sniff mode is disabled)

- Set Security Mode

This command is used to change the level of security of the Bluetooth connection.

Command	header		Command parameter(s)	Return parameter(s)
	ID	Size		

Set Security Mode	0x21	N	Security mode, pin code	Ack
-------------------	------	---	-------------------------	-----

Parameter	Size	Parameter description
Security mode	1 byte	0x00 → pin code disabled 0x01 → pin code enabled
Pin code	N - 1 bytes	Pin code (N - 1 • 16)

To disable the security, the pin code parameter is not used.

0x21	0x0001	0x00
------	--------	------

But to activate the security, the pin code must be entered in order to authenticate the user.

0x21	0x0005	0x00	0x30 0x30 0x30 0x30
ID	Size	Mode	Pin code

- Set Link Time Out

This timer is used to know if the connection is active or not. If there is no response from the remote device before the end of this timer, it means that the connection is lost.

Command	header		Command parameter(s)	Return parameter(s)
	ID	Size		
Set Link TMO	0x19	0x0002	Nb slots	Ack

Parameter	Size	Parameter description
Nb slots	2 bytes	Number of slots before a link time out

- Set Remote BDA

This command is used to configure a remote device. When the device is master, the scanner creates a connection to this BD@.

Command	header		Command parameter(s)	Return parameter(s)
	ID	Size		
Set Remote BDA	0x05	0x0006	Bd_Addr	Ack

Parameter	Size	Parameter description
Bd_Addr	6 bytes	Remote BDA used in master mode

- Set PageScan

This command is used to change the delay in which the Bluetooth module is discoverable.

Command	header		Command parameter(s)	Return parameter(s)
	ID	Size		
Set PageScan	0x14	0x0004	Ps_Interval, Ps_Window	Ack

Parameter	Size	Parameter description
Ps_Interval	2 bytes	Page scan interval (between 0x0012 and 0x1000 slots)
Ps_Window	2 bytes	Page scan window (between 0x0012 and 0x1000 slots)

- Set InquiryScan

This command is used to change the delay in which the Bluetooth module tries to find other Bluetooth devices.

Command	header		Command parameter(s)	Return parameter(s)
	ID	Size		
Set InquiryScan	0x16	0x0004	Is_Interval, Is_Window	Ack

Parameter	Size	Parameter description
Is_Interval	2 bytes	Inquiry scan interval (between 0x0012 and 0x1000 slots)
Is_Window	2 bytes	Inquiry scan window (between 0x0012 and 0x1000 slots)

- Set Power

This command is used to configure the transmit power.

Command	header		Command parameter(s)	Return parameter(s)
	ID	Size		
Set Power	0x38	0x0004	Def_Power, Max_Power	Ack

Parameter	Size	Parameter description
Def_Power	2 bytes	Default transmit power (in dBm)
Max_Power	2 bytes	Maximum transmit power (in dBm)

- Set Timers

This command is used to configure the shutdown timers.

Command	header		Command parameter(s)	Return parameter(s)
	ID	Size		
Set Timers	0x32	0x0004	Tlisten, Tconnect	Ack

Parameter	Size	Parameter description
Tlisten	2 bytes	Timer used to shutdown the barcode reader when this later is not connected (resolution: second)
Tconnect	2 bytes	Timer used to shutdown the barcode reader when this later is connected (resolution: minute)

- Set Prefix / Suffix

This command is used to configure a prefix and/or a suffix.

Command	header		Command parameter(s)	Return parameter(s)
	ID	Size		
Set Prefix / Suffix	0x34	N • 41	Prefix's length, Prefix, Suffix	Ack

Parameter	Size	Parameter description
Prefix's length	1 byte	Size of the prefix parameter {M byte(s)}
Prefix	M byte	Prefix character(s) (max: 20 characters)
Suffix	N – M - 1 bytes	Suffix character(s) (max: 20 characters)

Note:

If the prefix's size = 0, only a suffix is configured.

If N = (prefix's size – 1), only a prefix is configured.

To configure a prefix or/and a suffix, the hexadecimal value of a character must be sent in decimal. For example:

Prefix = 'A' (0x41) & Suffix = 'X' (0x58)

Command ID	Size	Prefix's size	Prefix		Suffix	
0x34	0x0005	0x01	0x34 '4'	0x31 '1'	0x35 '5'	0x38 '8'

- Set Sending Format

This command is used to configure the format of transmission of barcodes (see 2.4 Sending of barcodes)

Command	header		Command parameter(s)	Return parameter(s)
	ID	Size		
Set Sending Format	0x36	0x0003	Ack, Prefix/Suffix mode, Baracoda encapsulation	Ack

Parameter	Size	Parameter description
Ack	1 byte	0x00 → ack disable 0x01 → ack enable
Prefix/Suffix mode	1 byte	Add a prefix or/and a suffix 0x00 → disable 0x01 → enable
Encapsulation mode	1 byte	Baracoda encapsulation mode 0x00 → disable 0x01 → enable

1.2.3. Specials commands

- Reset

Command	Packet			Return parameter(s)
Reset	0x52 'R'	0x73 's'	0x74 't'	None

Restore the factory settings (it does not change the device name):

Parameter	Default value	Meaning
Pin code	0x30 0x30 0x30 0x30	'0000'
Mode	0x03	Lan
MinSniff	0x0050	80 slots
MaxSniff	0x0320	800 slots
Security Mode	0x01	Pin Code enabled
Link TMO	0x7D00	32 000 slots
Tlisten	0x0258	10 min
Tconnect	0x0014	20 min
SendingFormat	0x00 0x00 0x01	Ack → off Prefix/Suffix → off Baracoda encapsulation → on
Prefix	0x00	None

Suffix	0x00	None
PageScan	0x0320 0x0090	Interval = 800 slots Window = 144 slots
InquiryScan	0x0640 0x0018	Interval = 1600 slots Window = 20 slots

1 slot = 0,625 ms

1.3. SmartModule to the remote application

1.3.1. Events

Event ID	Size (bytes)	Name
0x07	N • 16	Pin_Code
0x08	N • 248	Name
0x04	1	Mode
0x10	4	Sniff
0x20	1	Security_Mode
0x18	2	Link_Tmo
0x06	6	Remote_BDA
0x13	4	PageScan
0x15	4	InquiryScan
0x39	4	Power
0x33	4	Timers
0x35	N • 41	Prefix / Suffix
0x37	3	Sending Format
0x76	N	Versions

1.3.2. Details of events

- Pin Code

Event	header		Event parameter(s)
	ID	Size	
Set Pin Code	0x07	N	Pin code

Parameter	Size	Parameter description	Default value
Pin code	N bytes	Pin code (N • 16)	'0000'

- Name

Event	header		Event parameter(s)
	ID	Size	
Name	0x08	N	Name

Parameter	Size	Parameter description	Default value
Name	N bytes	Name (N • 248)	

- Mode

Event	header		Event parameter(s)
	ID	Size	
Mode	0x04	0x0001	Mode

Parameter	Size	Parameter description	Default value
Mode	1 byte	0x02 → RealTime 0x03 → Lan	0x03 (Lan)

- Sniff

Event	header		Event parameter(s)
	ID	Size	
Sniff	0x10	0x0004	MinSniff, MaxSniff

Parameter	Size	Parameter description	Default value
MinSniff	2 bytes	Minimum interval, in slots, for sniff mode negotiation	0x0050 (80 slots)
MaxSniff	2 bytes	Maximum interval, in slots, for sniff mode negotiation	0x0320 (800 slots)

- Security Mode

Event	header		Event parameter(s)
	ID	Size	
Security Mode	0x20	0x0001	Security mode

Parameter	Size	Parameter description	Default value
Security mode	1 byte	0x00 → pin code off 0x01 → pin code on	0x01 (On)

- Link TMO

Event	header		Event parameter(s)
	ID	Size	
Link TMO	0x18	0x0002	Link TMO

Parameter	Size	Parameter description	Default value
-----------	------	-----------------------	---------------

Link TMO	2 bytes	Link time out	0x7D00 (32 slots)
----------	---------	---------------	----------------------

- Remote BDA

Event	header		Event parameter(s)
	ID	Size	
Remote BDA	0x06	0x0006	Remote BDA

Parameter	Size	Parameter description
Remote BDA	6 bytes	Remote BDA used in master mode

- PageScan

Event	header		Event parameter(s)
	ID	Size	
PageScan	0x13	0x0004	Ps_Interval, Ps_Window

Parameter	Size	Parameter description	Default value
Ps_Interval	2 bytes	Page scan interval (between 0x0012 and 0x1000 slots)	0x0320 (800 slots)
Ps_Window	2 bytes	Page scan window (between 0x0012 and 0x1000 slots)	0x0090 (144 slots)

- InquiryScan

Event	header		Event parameter(s)
	ID	Size	
InquiryScan	0x15	0x0004	Is_Interval, Is_Window

Parameter	Size	Parameter description	Default value
Is_Interval	2 bytes	Inquiry scan interval (between 0x0012 and 0x1000 slots)	0x0640 (1600 slots)
Is_Window	2 bytes	Inquiry scan window (between 0x0012 and 0x1000 slots)	0x0018 (24 slots)

- Power

Event	header		Event parameter(s)
	ID	Size	
Power	0x39	0x0004	Def_Power, Max_Power

Parameter	Size	Parameter description
Def_Power	2 bytes	Default transmit power (in dBm)
Max_Power	2 bytes	Maximum transmit power (in dBm)

- Timers

Event	header		Event parameter(s)
	ID	Size	
Timers	0x33	0x0004	Tlisten, Tconnect

Parameter	Size	Parameter description	Default value
Tlisten	2 bytes	Timer used to shutdown the barcode reader when this later is not connected (resolution: second)	0x0258 (600 s)
Tconnect	2 bytes	Timer used to shutdown the barcode reader when this later is connected (resolution: minute)	0x0014 (20 m)

- Sending Format

Event	Header		Event parameter(s)
	ID	Size	
Sending Format	0x37	0x0003	Ack, Prefix/Suffix mode, Encapsulation mode

Parameter	Size	Parameter description	Default value
Ack	1 byte	0x00 → disable 0x001 → enable	0x00 (off)
Prefix/Suffix mode	1 byte	Add a prefix or/and a suffix 0x00 → disable 0x01 → enable	0x00 (off)
Encapsulation mode	1 byte	Baracoda encapsulation mode 0x00 → disable 0x01 → enable	0x01 (on)

- Prefix / Suffix

Event	Header		Event parameter(s)
	ID	Size	
Prefix / Suffix	0x35	N • 41	Prefix's size, Prefix, Suffix

Parameter	Size	Parameter description	Default value
Prefix's size	1 byte	Size of the prefix parameter {M byte(s)}	0x00
Prefix	M byte	Prefix character(s) (max: 20 characters)	None
Suffix	N – M - 1 bytes	Suffix character(s) (max: 20 characters)	None

Note:

If the prefix's size = 0, only a suffix is configured.

If N = (prefix's size – 1), only a prefix is configured

The return is the hexadecimal value of a character. For example:

Event ID	Size	Prefix's size	Prefix		Suffix	
0x35	0x0006	0x01	0x34 '4'	0x31 '1'	0x35 '5'	0x38 '8'

Prefix = 0x41 ('A') Suffix = 0x58 ('X')

- Versions

Event	header		Event parameter(s)
	ID	Size	
Version	0x76	N	Version

Parameter	Size	Parameter description
Version	N bytes	SmartModule's version

2. Between the REMOTE APPLICATION and the decode board

2.1. Remote application to the decode board

2.1.1. Commands

Header	Command	Footer
<STX> 0x02	<SN> <TYPE> <PARM/DATA> <FM> <CHK>	<ETX> 0x03

To configure the scan engine, the SmartModule must be in pipe mode (default mode). If you have previously broke the pipe in order to configure the SmartModule, send the command "0x01 0x02 0x01" (see Introduction).

For more information about the decode board configuration, see the "Intermec Scanner Protocol – Technical Reference Manual" document.

Note: Do not change the serial interface configuration (command <SG> = 0x63) or the suffix value.

2.2. Sending of barcodes (decode board to the remote application)

2.2.1. Possibilities

This paragraph is describing the format of packets, which are sent from the barcode scanner to the remote application after having scanned a barcode.

There are 9 possibilities to receive a scanned barcode:

Ack	Pref/ Suff	Baracoda encap	Example										
OFF	OFF	OFF	<table border="1" style="margin: auto;"> <tr> <td>Barcode</td> </tr> <tr> <td>N bytes</td> </tr> </table>	Barcode	N bytes								
Barcode													
N bytes													
ON	OFF	OFF	<table border="1" style="margin: auto;"> <tr> <td>Barcode</td> </tr> <tr> <td>N bytes</td> </tr> </table>	Barcode	N bytes								
Barcode													
N bytes													
OFF	ON	OFF	<table border="1" style="margin: auto;"> <tr> <td>Prefix</td> <td>Barcode</td> <td>Suffix</td> </tr> <tr> <td>M bytes</td> <td>N bytes</td> <td>P bytes</td> </tr> </table>	Prefix	Barcode	Suffix	M bytes	N bytes	P bytes				
Prefix	Barcode	Suffix											
M bytes	N bytes	P bytes											
OFF	OFF	ON	<table border="1" style="margin: auto;"> <tr> <td>0x32</td> <td>Size</td> <td>Barcode</td> </tr> <tr> <td>1 byte</td> <td>2 bytes</td> <td>N bytes (= size)</td> </tr> </table>	0x32	Size	Barcode	1 byte	2 bytes	N bytes (= size)				
0x32	Size	Barcode											
1 byte	2 bytes	N bytes (= size)											
ON	OFF	ON	<table border="1" style="margin: auto;"> <tr> <td>0x33</td> <td>Size</td> <td>ID</td> <td>Barcode</td> </tr> <tr> <td>1 byte</td> <td>2 bytes</td> <td>1 byte</td> <td>N bytes (= size - 1)</td> </tr> </table>	0x33	Size	ID	Barcode	1 byte	2 bytes	1 byte	N bytes (= size - 1)		
0x33	Size	ID	Barcode										
1 byte	2 bytes	1 byte	N bytes (= size - 1)										
ON	ON	OFF	<table border="1" style="margin: auto;"> <tr> <td>Prefix</td> <td>Barcode</td> <td>Suffix</td> </tr> <tr> <td>M bytes</td> <td>N bytes</td> <td>P bytes</td> </tr> </table>	Prefix	Barcode	Suffix	M bytes	N bytes	P bytes				
Prefix	Barcode	Suffix											
M bytes	N bytes	P bytes											
OFF	ON	ON	<table border="1" style="margin: auto;"> <tr> <td>0x32</td> <td>Size</td> <td>Prefix</td> <td>Barcode</td> <td>Suffix</td> </tr> <tr> <td>1 byte</td> <td>2 bytes</td> <td>M bytes</td> <td>N bytes</td> <td>P bytes</td> </tr> </table>	0x32	Size	Prefix	Barcode	Suffix	1 byte	2 bytes	M bytes	N bytes	P bytes
0x32	Size	Prefix	Barcode	Suffix									
1 byte	2 bytes	M bytes	N bytes	P bytes									
ON	ON	ON	<table border="1" style="margin: auto;"> <tr> <td>0x33</td> <td>Size</td> <td>ID</td> <td>Prefix</td> <td>Barcode</td> <td>Suffix</td> </tr> </table>	0x33	Size	ID	Prefix	Barcode	Suffix				
0x33	Size	ID	Prefix	Barcode	Suffix								

			1 byte	2 bytes	1 byte	M bytes	N bytes	P bytes
--	--	--	--------	---------	--------	---------	---------	---------

2.2.2. Management of acknowledgment

All barcodes sent by the barcode reader to the remote application which have header '0x33' need to be acknowledged before to be deleted. So, after a sending of data, the barcode reader has to wait for a BARCODE_ACK from the host (remote application) to send the next scanned barcode.

When a BARCODE_ACK is received, the data is deleted.

If nothing is received, the next barcode will be sent after having received the acknowledgment of the previous one.

For the next scanned barcode, the scanner will try to send again the first barcode of the buffer in following the previous process. (i.e: first in, first out)

- Barcode_Ack command format

Command	Header	Command parameter(s)	Return parameter(s)
BARCODE_ACK	0x06 0x01	Barcode ID	None

Parameter	Size	Parameter description
Barcode ID	1	Barcode ID

In order to send an acknowledgement, the SmartModule must be in pipe mode. If you have previously broke the pipe in order to configure the SmartModule, send the command "0x01 0x02 0x01" (see Introduction).

- Examples

The following paragraph explains the sending of a barcode with specific encapsulation and the acknowledgement

Success of acknowledge

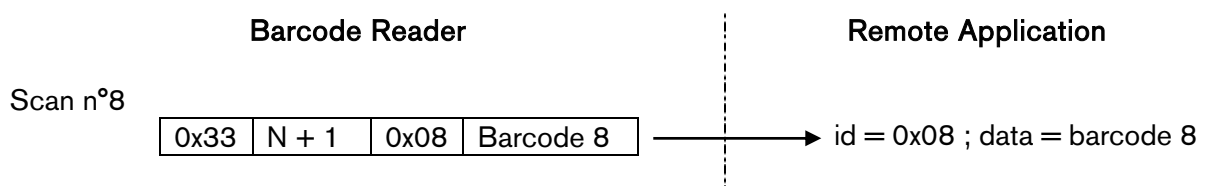

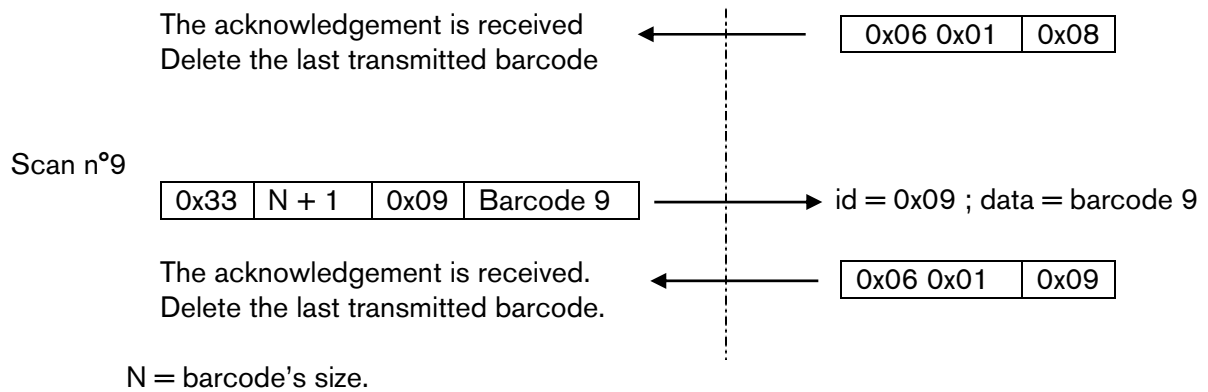

Failure of sending

